



## Tri-generation and combined cycles: thermodynamic analysis of prime movers in standalone and hybrid configurations

Michael Haughey<sup>1,\*</sup>, Karim He<sup>2</sup> and Toan Dinh<sup>3</sup>

Faculty of Science, University of Technology Sydney, P.O. Box 123, Australia

<sup>1</sup>E-Mail: Michael.K.Haughey@student.uts.edu.au;

<sup>2</sup>E-Mail: Karimyouhua.He@student.uts.edu.au;

<sup>3</sup>E-Mail: The.T.Dinh@student.uts.edu.au

\*Author to whom correspondence should be addressed

Received: 25/5/2015 / Accepted: 29/5/2015 / 1/6/2015:

---

**Abstract:** The global movement towards lower carbon economies and distributed energy requires the realisation of improved energy generation methods. Tri-generation is a method of optimising the thermal efficiency of energy generation through waste heat recapturing and can simultaneously provide heating, cooling and electrical output to meet building energy demands. A meta-analysis was conducted to analyse the performance of various prime movers utilised in tri-generation applications. Through this study it was determined that the efficiency of tri-generation and combined cycles can be optimised through a hybridisation of prime movers.

**Keywords:** tri-generation, Stirling engine, fuel cell, microturbine, Brayton cycle, hybrid system

---

Copyright: © 2015 by the authors. This article is distributed under the terms and conditions of the Creative Commons Attribution license (<https://creativecommons.org/licenses/by/4.0/>).

DOI: <http://dx.doi.org/10.5130/pamr.v2i0.1397>

*PAM Review* is a Student Journal from UTS ePRESS showcasing outstanding UTS student works

## 1. Introduction

Tri-generation systems allow for the simultaneous generation of heat, electricity and cooling energy from a single energy process [1]. Tri-generation can be utilised in residential housing, commercial buildings to meet energy needs without increasing demand on the electrical grid networks.

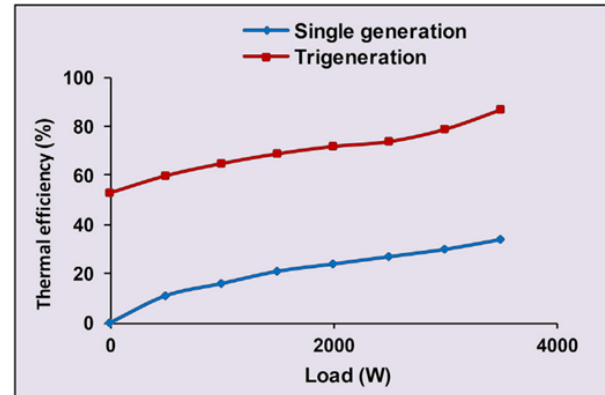

Figure 1 Sample of the variation of thermal efficiency with load [2]

Micro-scale tri-generation systems are defined as systems with a total energy output below 15kW [2]. As per Figure 1, Sonar et al. [2] analysed a typical tri-generation system with an output of 3.7kW under lab conditions and found that the thermal efficiency of the tri-generation system was 155% [2] higher than that of single generation at full load.

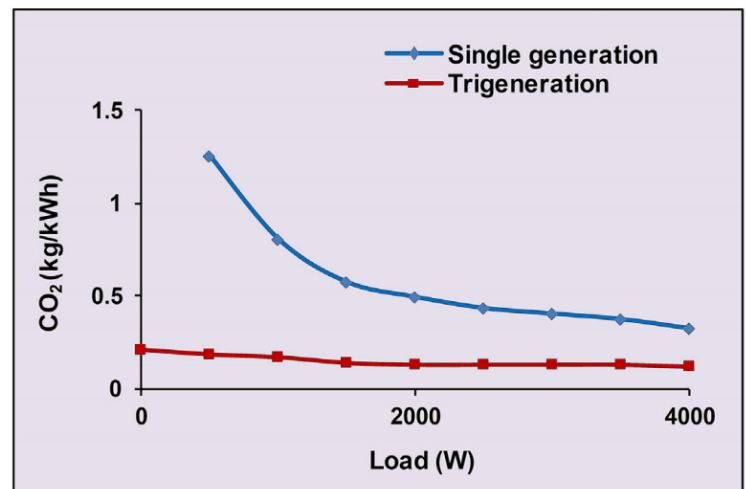

Figure 2 Sample of variation of carbon dioxide with load [2]

Electricity generated by tri-generation can be supplied to electrical grids assisting supply authorities in minimising peak electricity demand. Tri-generation systems can also assist in improving grid resilience and enable a decentralisation of grid networks. Additionally tri-generation systems offer significantly increased thermal efficiencies when compared to conventional energy generation methods due to the additional processes of waste heat recapturing.

Tri-generation systems are driven by prime movers such as turbines, Stirling engines, reciprocating engines and fuel cells and can utilise a broad range of fuel types such as diesel, natural gas, biogas, and biodiesel [1].

Micro-scale tri-generation offers significant advantages in the global movement towards a low-carbon economy. Tri-generation also offers significantly reduced CO<sub>2</sub> output across a

varying range of loads typical of micro-scale systems. Figure 2 demonstrates CO<sub>2</sub> emission per unit (kWh) of useful energy output results in a 61% [2] reduction of CO<sub>2</sub> when a tri-generation system operates at full load compared to a single generation system.

A typical tri-generation layout incorporates a prime mover that is directly connected to an electrical generator; see Figure 3. Exhaust gasses are transferred to a heat exchanger before being released into the atmosphere. Cold water is injected and transferred to both the heat exchanger and a vapour absorption refrigerator. The electrical generator provides building electrical requirements, the vapour absorption refrigerator provides cooling and the heat exchanger provides the heating means.

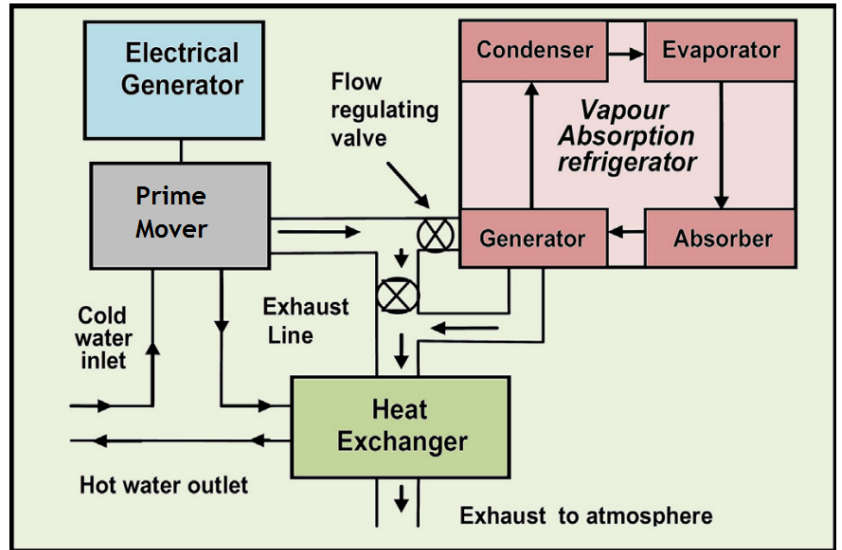

Figure 3 Typical tri-generation configurations [2]

**Micro turbines**

Gas micro turbines are a form of combined heat and power production, a typical micro turbine shown in Figure 4 works by compressing gases (1), which is fed to a recuperator to recover some exhaust heat from the turbine (2) [3]. In the combustion chamber (CC) a variety of fuels can be injected such as biomass, natural gas or hydrocarbon fuels, the gases from the CC turn the turbine which is connected through a single shaft to an electrical generator [3]. The excess heated gases go from the turbine to the recuperator which recovers additional heat from the gases for heating purposes (4). The combination of electrical and thermal power output results in

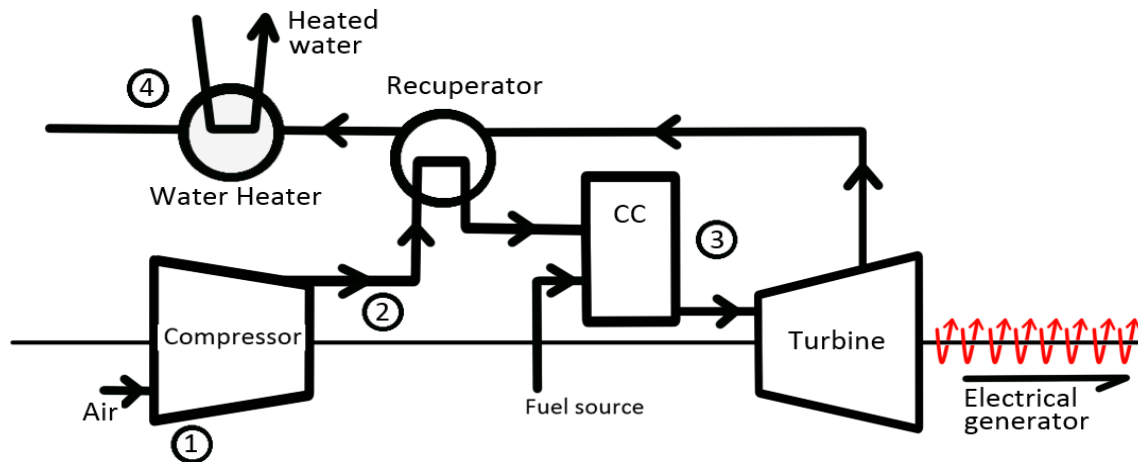
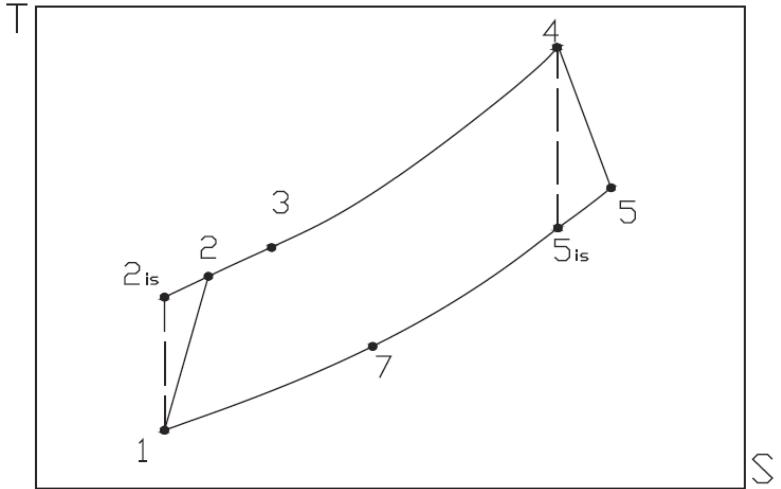

Figure 4 Operation of a micro turbine [3]

efficiency greater than 80% [3].

Micro turbines operate as per the Brayton cycle which describes a heat engine of constant pressure that is demonstrated through temperature (K) vs. entropy (S) graph.

In terms of micro turbines shown in Figure 5, at state 1 the gas enters the compressor and is adiabatically compressed to state 2 the compressed gas is then combusted, thus the temperature and entropy increase at state 4, next the gas expands in the turbine to state 5. There is a drop in temperature and the entropy is seen to increase [5]. The vertical lines at state 1 to 2 is and state 4 to 5 is represent an ideal isentropic process without friction.



Ho et al. [6] analysed a micro turbine system for tri-generation application, the micro turbine used was a Capst one microturbine Model 330, the absorption chiller used was WFC-10W Yazaki chiller. At 5 hours operation the overall system efficiency was 46% at 25 operational hours the efficiency was 48%, hence for extended operating hours it was found efficiency increases by 2% [6].

In order to improve efficiency the pressure ratio can be increased. Riccio et al. tested a microturbine with two combustion chambers firing both biomass and natural gas for tri-generation [7]. The relationship drawn was by increasing the pressure ratio the efficiency of the system also increased. This was repeated this for various turbine inlet temperatures (TIT) and plotted the efficiency ratio against the pressure ratio. The efficiency of the Brayton cycle in terms of the pressure ratio shown below demonstrates an increased pressure ratio leads to increase in efficiency.

$$\eta = 1 - \left(\frac{P_1}{P_2}\right)^{\gamma/(1-\gamma)}$$

Siljack et al. conducted a study to determine the amounts of CO and NOx produced from liquefied wood (LW), tire pyrolysis oil (TPO), 1:1 ratio of diethylene glycol and glycerol (GLY)

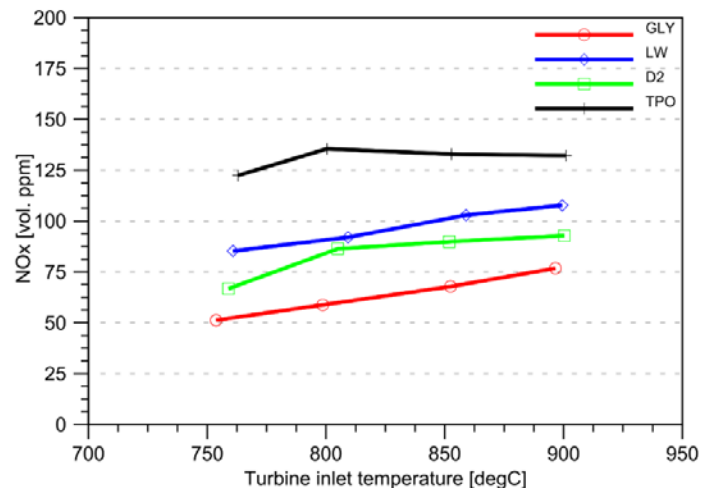
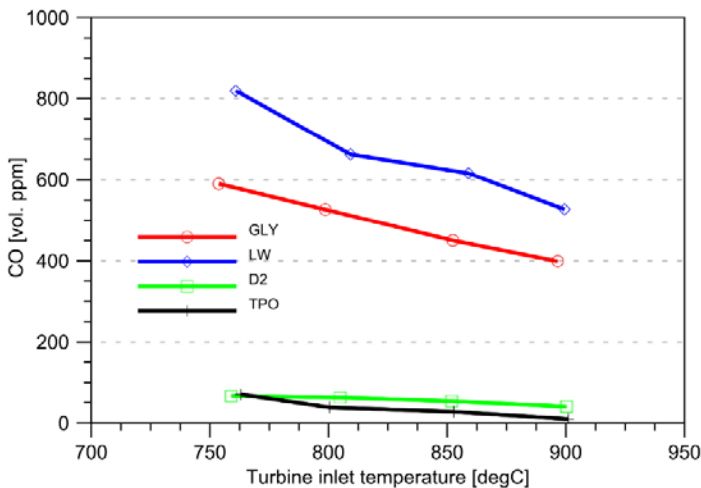

and diesel fuel (D2) [8]. Shown in Figures 10 and 11 clearly demonstrate there is a clear relationship between the types of fuel used and various waste products. It should also be noted with varying turbine inlet temperature the volume of waste products changes, from the graphs above carbon monoxide produced decreases with an increase of turbine inlet temperature whereas nitrogen oxides demonstrate an increasing trend [8].

## Stirling Engine

Stirling Engines operate on the principle of the Stirling cycle and are another common engine type utilised within tri-generation. The Stirling cycle incorporates a constant volume process during the transfer of hot and cold fluids between engine spaces and a constant temperature cooling process during compression and expansion [9]. This engine is a regenerative engine with a theoretical thermal efficiency that is equal to the Carnot efficiency. Stirling engines are also known for their long engine life and low noise output [10].

Stirling engines can accommodate a wide range of fuel types and the rotational elements produce less noise present with most ICE (internal combustion engines). [11]. This flexibility in fuel types allows for increased mitigation in CO<sub>2</sub> output as bio-fuels can be utilized effectively enabling carbon neutral electricity production and thermal energy. Electrical to thermal outputs of 10% to 60% respectively can be achieved. Two common Stirling engine configurations include the lever type and rhombic drive. The lever drive incorporates lesser components as well as a lower external volume and mass when compared to a Rhombic driven engine.

The Stirling cycle is a constant volume process in which the transfer of hot and cold fluids occurs between engine spaces and a constant temperature cooling process during both compression and expansion.

Solmaz et al undertook a study comparing the efficiencies of lever and rhombic drive Stirling engine systems [12]. Figure 8 represents a PV comparison of these systems when a charge pressure of 4 bar is maintained. Helium was utilised as the working fluid and charge pressure and dead volumes were kept equal for both systems. The lever drive system was capable of producing approximately

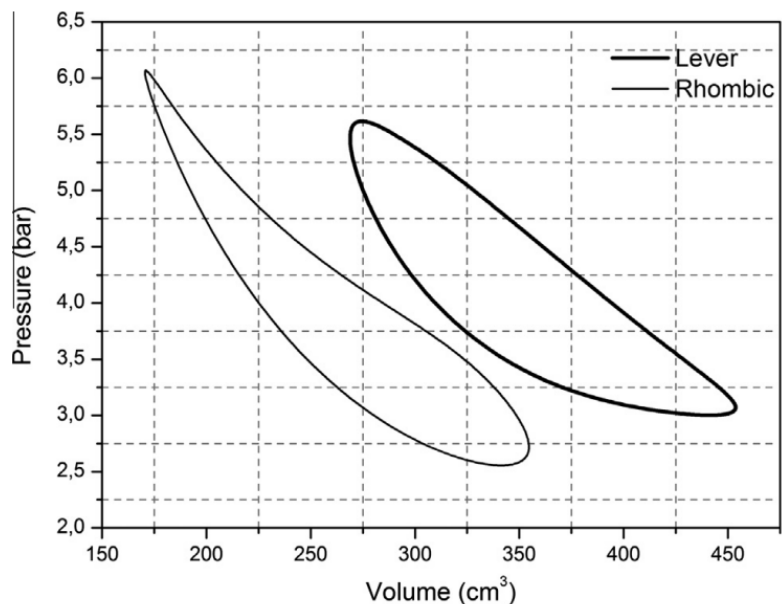

Figure 8 comparison of lever driven and rhombic drive at the same charge pressure of 4 bar [12]

17W of work whilst the rhombic system produced approximately 14W of work.

From the PV comparison the conclusion can be drawn that the rhombic drive generates more work than the lever driven engine. The tapering in the upper left quadrant of the rhombic engine is too thin and necessitates a high compression ratio. At a source temperature of 1000K the maximal efficiencies achieved were 28% and 35% for the lever and rhombic engines respectively. However when the systems are standardized based on equal thermal fluid mass it was determined that lever drive systems offered increased thermal efficiency than that of the rhombic drive system as demonstrated by Figure 9.

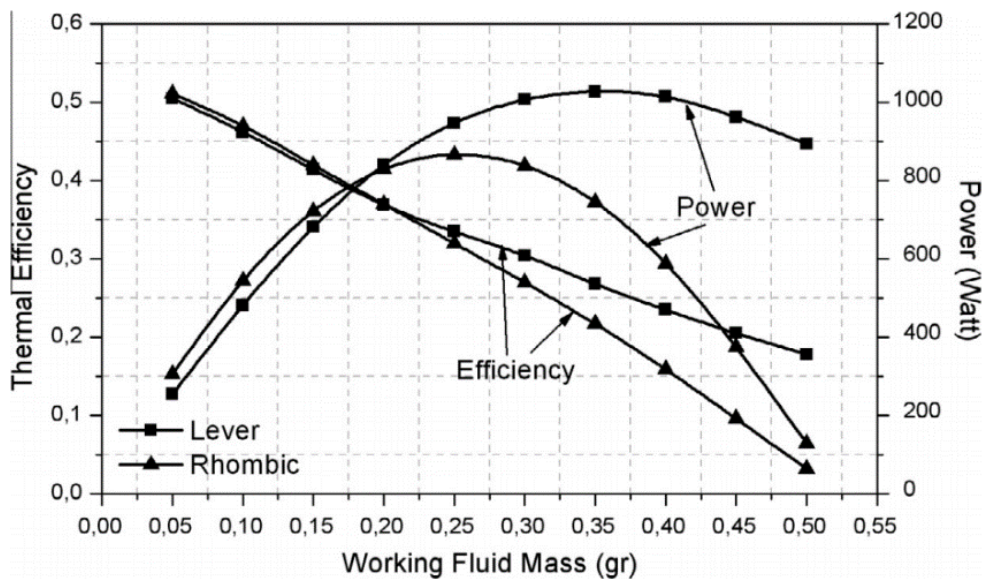

Figure 9 Comparison of lever driven and rhombic drive at the same charge pressure of 4 bar [12]

### Fuel Cells

Solid oxide fuel cell (SOFC) are considered an emerging technology as characterised by their high efficiency and low CO<sub>2</sub> emissions [13]. SOFCs generate electricity from fuels such as methane and an oxidant such as air and operate at higher temperatures compared to other prime movers and generate significant waste heat. Fuel cells have can achieve efficiencies of between 15-38% for electrical output and up to 80% for thermal output [1].

SOFC utilise redox reactions to generate electrical and heat energy. The SOFC consists of a chamber that acts as an anode and cathode. The fuel and air being undergo oxidation and reduction reactions. The reduction of oxygen into ionic counterpart disperses ions throughout the solid oxide electrolyte to the anode where ions electrochemically oxidise the fuel [14]. An SOFC is typically combined with an organic Rankine cycle (ORC). The chemical reactions within the anode and cathode of an SOFC utilising methane as the fuel source are as follow are represented by Figure 11.

The theoretical EMF that can be generated by a fuel cell is determined by the Nernst Equation [13]. Several losses exist prevent the theoretical EMF from being achieved including activation losses, ohmic losses and concentration losses. Figure 12 demonstrates how these losses affect the cell potential across a range of current densities.

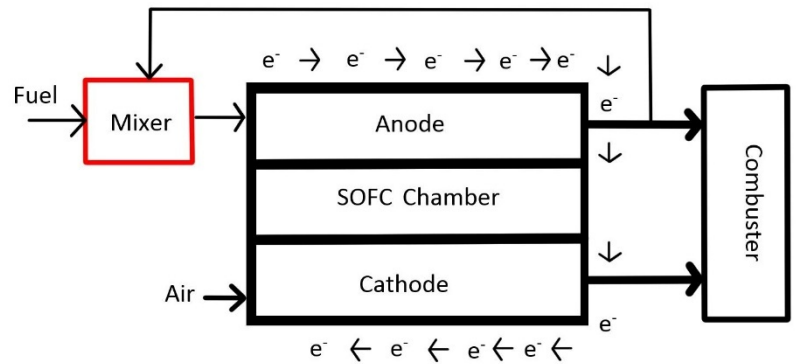

Figure 10 SOFC Fuel Cell Layout

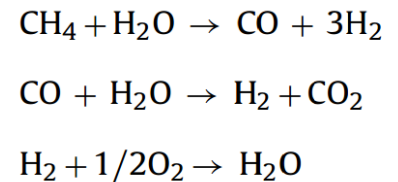

Figure 11 SOFC chemical and Electrochemical reactions [13]

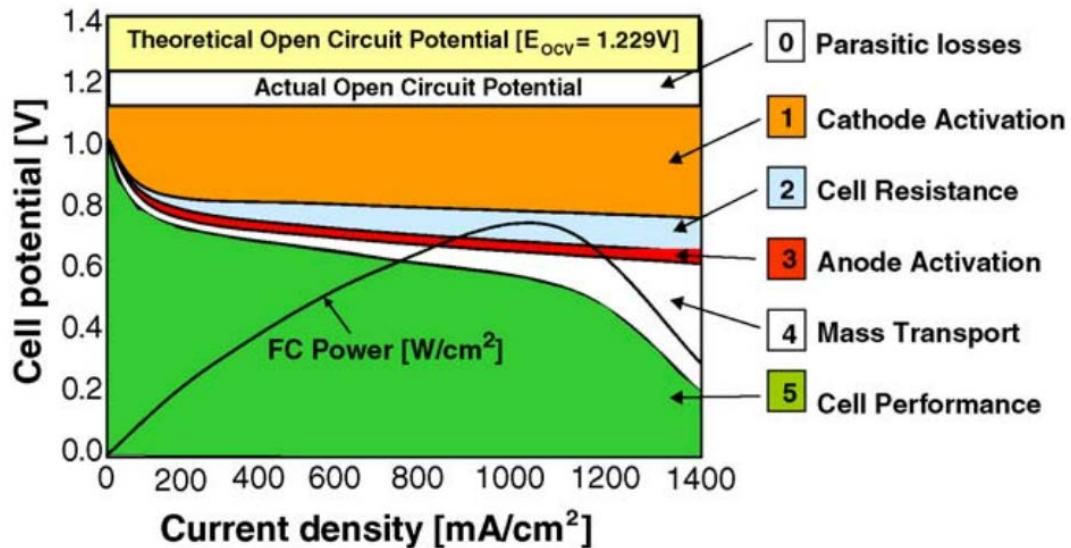

Figure 12 Ideal and actual fuel cell voltage-current characteristics for a single cell [13]

## Hybrid Systems

A hybrid tri-generation system involves the use of a combination of prime movers to further improve electrical and thermal efficiencies. Two common hybrid configurations exist which are the fuel cell and microturbine and fuel cell Stirling engine.

### Fuel cell and Microturbine

A fuel cell and microturbine hybrid setup is demonstrated in Figure 13. A fuel cell and microturbine configured in this manner enables the use of two electrical outputs with one from the fuel cell and one from the generator.

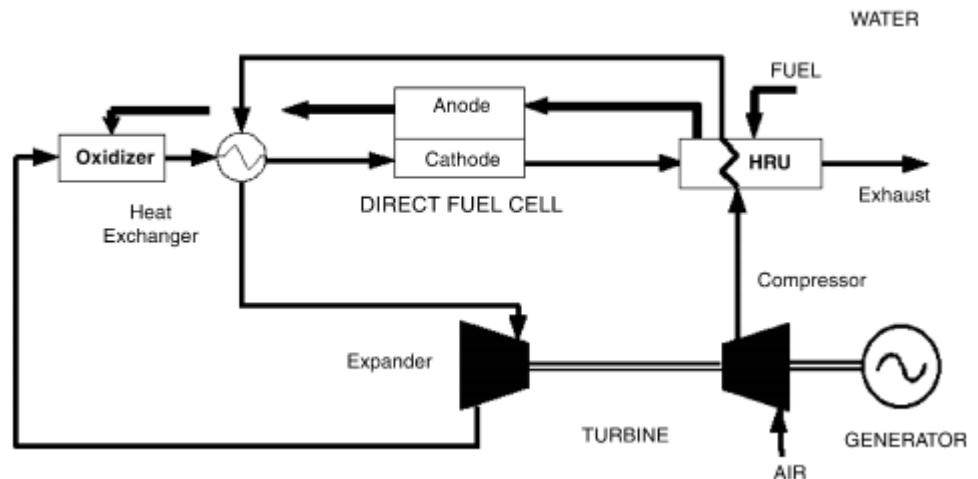

Figure 13 Diagram of a fuel cell and microturbine combined cycle [15]

Chacartegui et al. [16] performed an experiment to assess the performance of a hybrid turbine and molten carbonate fuel cell (MCFC) system. The resultant graph (Figure 14) demonstrates the large difference in efficiency for different system loads. While the fuel cell is comparable to the hybrid systems at around 56% efficiency, the turbines peak efficiency at 36% for humid air turbine (HAT) and 34% for gas turbine (GT) both at 95% load. Between the HAT+MCFC and GT+MCFC hybrid system, the MCFC+HAT hybrid system has the highest efficiency peaking at 62%. Microturbines in conjunction with a Fuel Cell are capable of bolstering the exergy efficiency by up to 5% [17].

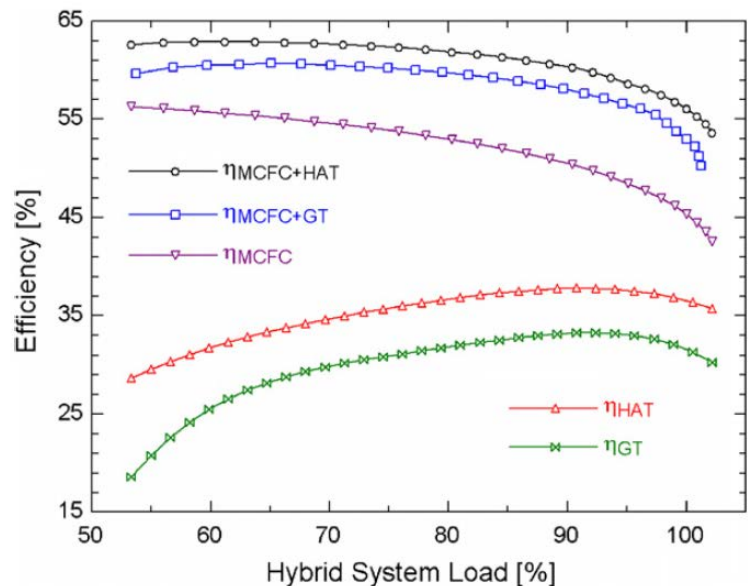

Figure 14 Efficiency vs Hybrid System Load [16]



### Fuel cell and Stirling Engine

A fuel cell and Stirling engine is an additional common configuration for hybrid systems. The heat generated by the fuel cell provides the heat source for operating of the Stirling engine. Electrical outputs are drawn from both the fuel cell and generator driven by the Stirling engine.

As evident within Figure 15 a) a Hybrid system offers significantly improved efficiencies compared to an individual fuel cell or Stirling engine over a wide range of current densities. Additionally Figure 15 b) demonstrates the significantly improved power density with respect to current density associated with the hybrid system design.

## 2. Methodology

The purpose of this meta-study is to analyse advancements in prime mover technology and the applications to tri-generation and combined cycle systems. Thermodynamic properties such as volume, pressure, efficiency, temperature and entropy associated with these systems were analysed.

The resources used within this meta-study were restricted to the Science Direct database dated from the turn of the last century. Keywords were restricted to ‘tri-generation systems’, ‘CCHP’, ‘microturbine tri-generation’, ‘Stirling engine tri-generation’ and ‘fuel cell tri-generation’ when locating resources in order to specifically target the relevant thermodynamic properties. Additionally, these restrictions were defined to assist in filtering only the most relevant research on tri-generation technology.

Following data analysis the efficiencies of each system were graphed to identifying the most efficient prime mover configurations both in standalone and hybrid configurations.

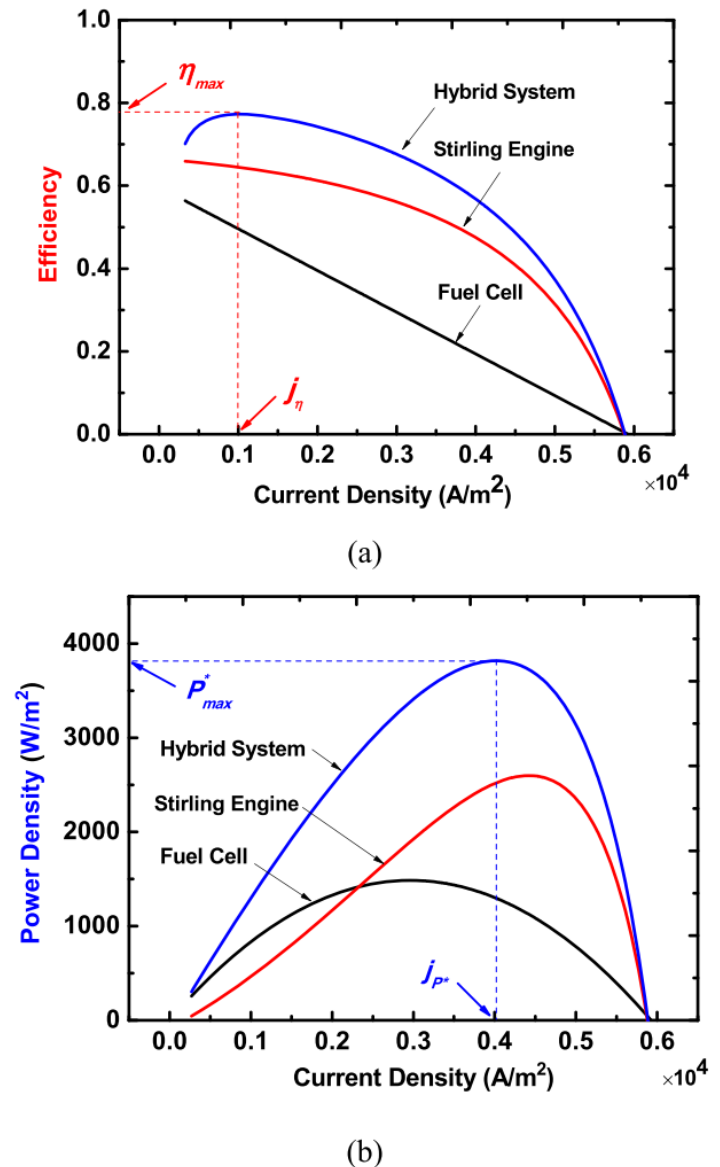

Figure 15. a) Sample Efficiency vs Current Density ( $A/m^2$ ) b) Sample Power Density ( $W/m^2$ ) vs Current Density ( $A/m^2$ ) [17]

### 3. Results and Discussion

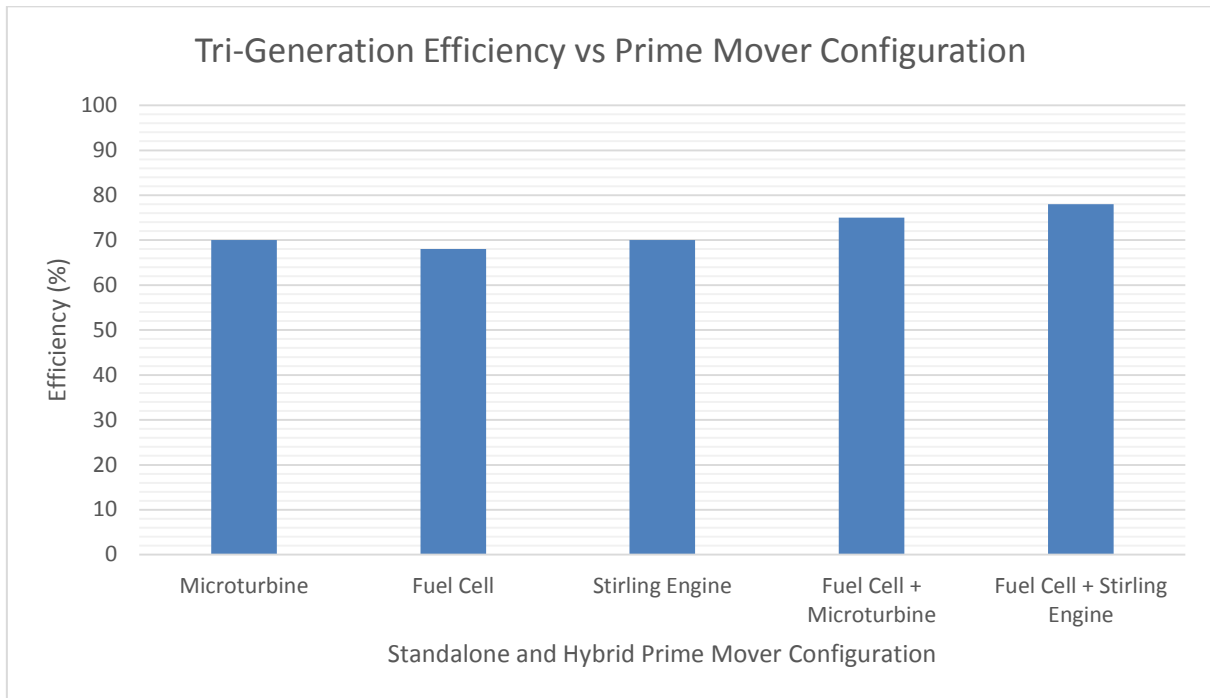

Figure 16 Efficiency vs Prime Mover [16]

Furthermore, despite high efficiencies offered by the hybrid system configurations, increased volume is needed to contain these systems. Additional maintenance may also be needed to ensure reliability.

Australian domestic and commercial markets have yet to experience any impacts of tri-generation systems. Potential government initiatives and technological advancements may see this technology mature and gain increased usage to meet both domestic electrical, heating and cooling demands. The improved thermal efficiencies offered by these systems can assist in reducing carbon output which is a necessary step in meeting various emissions restrictions and carbon agreements. As alternative zero carbon fuel types such as biofuels become more widely adopted and produced tri-generation will undoubtedly be a viable competing technology with other alternative energy resources. Tri-generation will also assist in decentralising the current structure of electrical distribution networks and can dramatically reduce the reliance on electrical grids for energy.

The results of this meta-study demonstrate the improved efficiency gains offered by hybrid configurations of prime movers in CCHP applications. As fuel cell, Stirling engines and microturbine technology continues to improve, hybrid tri-generation systems will also benefit from these improvements and possibly become the standard configuration for domestic and commercial use.

#### 4. Conclusions:

The results of this study concluded that tri-generation and combined cycle systems can dramatically improve the efficiency associated with meeting building energy demands. From the dataset Fuel Cells and Stirling Engines are the most efficient hybrid prime mover configuration but this does not take into account the additional volume requirements of such a system.

Additionally, hybrid prime mover configurations of tri-generation systems can further improve the efficiencies of these systems. As improvements are developed in each prime mover hybrid systems will also benefit from these advancements and can result in even higher efficiencies.

#### Acknowledgments:

The authors gratefully acknowledge the continued support and assistance provided by Dr. Jurgen Schulte, the reviewers for their valuable commentary and the Faculty of Science at the University of Technology, Sydney.

#### References and Notes:

1. Jradi, M. & Riffat, S. 2014, 'Tri-generation systems: Energy policies, prime movers, cooling technologies, configurations and operation strategies', *Renewable and Sustainable Energy Reviews*, vol. 32, pp. 396-415.
2. Sonar, D., Soni, S.L. & Sharma, D., 2014 'Micro-trigeneration for energy sustainability: Technologies, tools and trends', *Applied Thermal Engineering*, vol. 71, no. 2, pp. 790-796.
3. Delattin F., Bram S., Knoops S. & Ruyck J. 2008 , 'Effects of steam injection on microturbine efficiency and performance', *Energy*, vol. 33, pp. 241-247.
4. Ameri, M., Behbahaninia A. & Tanha, A.A. 2010, 'Thermodynamic analysis of a tri-generation system based on micro-gas turbine with a steam ejector refrigeration system', *Energy*, vol. 35, no.5, pp. 2203-2209.
5. Mohamed, R., El-Maksoud, A. 2013, 'Binary Brayton cycle with two isothermal processes', *Energy Conversion and Management*, vol.73, pp.303-308.
6. Ho, J.C., Chua, K.J. & Chou S.K. 2004, 'Performance study of a microturbine system for cogeneration application', *Renewable Energy*, vol. 29, no. 7, pp.1121-1133.
7. Riccio, G., Chiaramonti, D. 2009, 'Design and simulation of a small polygeneration plant cofiring biomass and natural gas in a dual combustion micro gas turbine (BIO\_MGT)', *Biomass and Bioenergy*, vol.33, no.11, pp.1520-1531.
8. Seljak, T., Oprešnik, S.R. & Katrašnik T. 2014, 'Microturbine combustion and emission characterisation of waste polymer-derived fuels', *Energy*, vol.77, pp. 226-234.

9. Kong, X.Q., Wang R.Z. & Huang, X.H. 2004, 'Energy efficiency and economic feasibility of CCHP driven by Stirling engine', *Energy Conversion and Management*, vol. 45, no. 9–10, pp. 1433-1442.
10. Yu C., Chen L., Zhao Y., Li H. & Zhang X. 2015, 'A brief review study of various thermodynamic cycles for high temperature power generation systems', *Energy Conversion and Management*, vol.94, pp. 68-83.
11. Ulloa C., Eguia P., Miguez J.L., Porteiro J., Pousada C. & Cacabelos A. 2013, 'Feasibility of using a Stirling engine-based micro-CHP to provide heat and electricity to a recreational sailing boat in different European ports', *Applied Thermal Engineering*, vol. 59, no. 1–2, pp. 414-424.
12. Solmaz, H. & Karabulut, H. 2014, 'Performance comparison of a novel configuration of beta-type Stirling engines with rhombic drive engine', *Energy Conversion and Management*, vol.78, pp.627-633.
13. Al-Sulaiman, F.A., Dincer, I. & Hamdullahpur, F. 2010, 'Exergy analysis of an integrated solid oxide fuel cell and organic Rankine cycle for cooling', *heating and power production, Journal of Power Sources*, vol. 195, no. 8, pp. 2346-2354.
14. Ranjbar F., Chitsaz A., Mahmoudi S.M.S, Khalilarya S. & Rosen M.A., 2014, 'Energy and exergy assessments of a novel trigeneration system based on a solid oxide fuel cell', *Energy Conversion and Management*, vol. 87, pp.318-327.
15. Francisco, J. 2002, 'Study of molten carbonate fuel cell – microturbine hybrid power cycles', *Journal of Power Sources*, vol.111, no.1, pp. 121-129.
16. Chacartegui, R., Blanco, M.J., Munoz de Escalona, J.M., Sanchez, D. & Sanchez T. 2013, 'Performance assessment of Molten Carbonate Fuel Cell – Humid Air Turbine Hybrid systems', *Applied Energy*, vol.102, pp. 687-699.
17. Chitsaz, A., Mohammad, S., Mahmoudi, S. & Rosen, M.A. 2015, 'Greenhouse gas emission and exergy analyses of an integrated trigeneration system driven by a solid oxide fuel cell', *Applied Thermal Engineering*, vol 86, pp. 81-90.
18. Chen L., Zhang H., Gao S. & Yan H. 2014, 'Performance optimum analysis of an irreversible molten carbonate fuel cell-Stirling heat engine hybrid system', *Energy*, vol. 64, pp. 923-930.

## Glossary

CC	combustion chamber	SOFC	solid oxide fuel cell
CCHP	combined cooling, heat and power	TIT	turbine inlet temperatures
EMF	electromotive force	TPO	tire pyrolysis oil
FC	fuel Cell		
GLY	glycerol		
ICE	internal combustion engines		
LW	liquefied wood		
PV	pressure-volume		